

# GLOBAL SALES NETWORK

## J Series

1.3/1.5/1.6/1.8/2.0T  
Electric Three-wheel Forklift

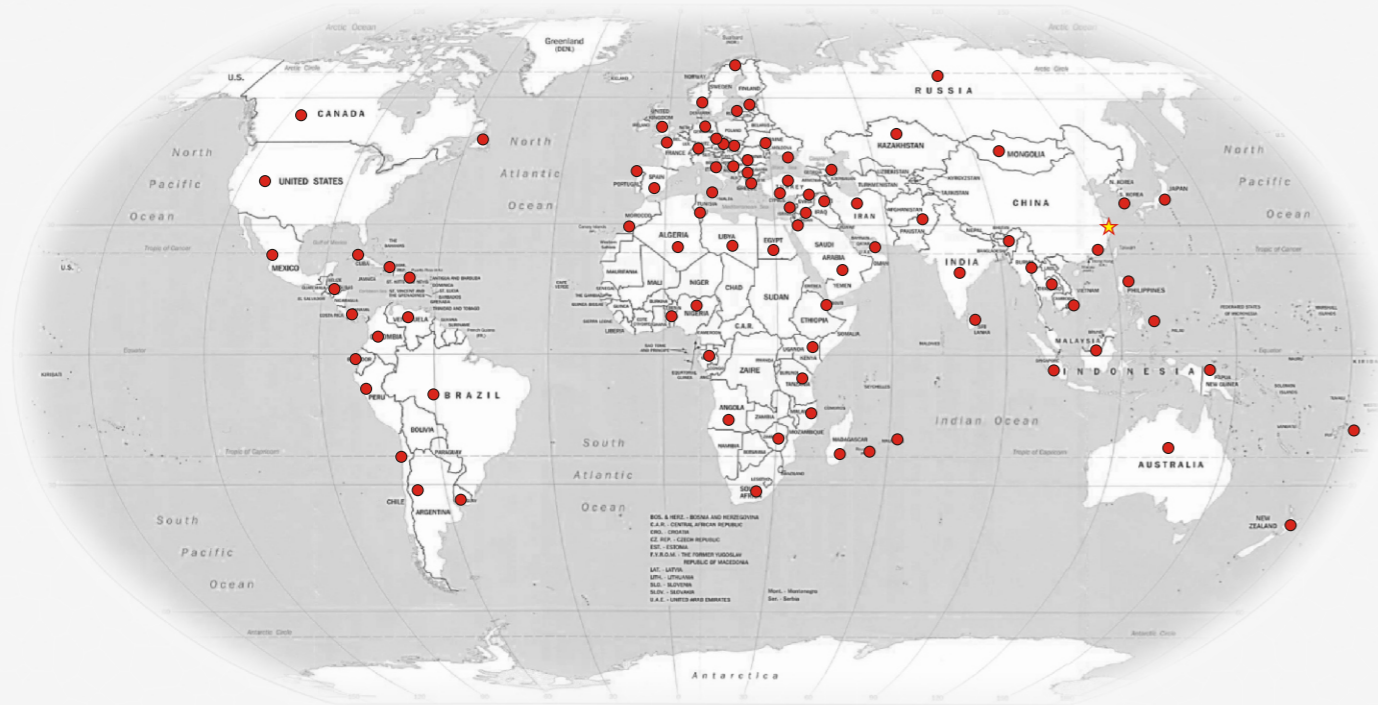

CE CERTIFICATE



ISO14001: 2004



ISO9001: 2008

**HANGCHA GROUP CO., LTD.**  
(Zhejiang Hangcha Imp.&Exp.Co.,Ltd.)

[www.hcforklift.com](http://www.hcforklift.com)

Add:398 Shi Qiao Road, Hangzhou Zhejiang province, China(310022)  
Factory site:No.88, Donghuan Rd., Economic Development Zone Lin'an, Zhejiang, China(311305)  
Tel: +86-571-88926755  
Fax: +86-571-88926789 88132890  
E-mail: sales@hcforklift.com

HANGCHA GROUP CO., LTD. Reserves the right to make any changes without notice concerning colors, equipment, or specifications detailed in this brochure, or to discontinue individual models. The colors of trucks, delivered may differ slightly from those in brochures.

2012 VERSION 1/ COPYRIGHT 2011/09

**HANGCHA GROUP CO., LTD.**

## DRIVE TRAIN

The incorporation of Shaoxing Advance developed components, including finely engineered helical gears, assures low noise, high quality and a longer service life.

For heavy-duty application the AC system and brushless motors with minimum servicing is ideal for long cycles, ramps and high lifts.

Twin AC motors are readily accessible from either the front or above, minimising service time.

The controller control the traveling, lifting, tilling and steering action.

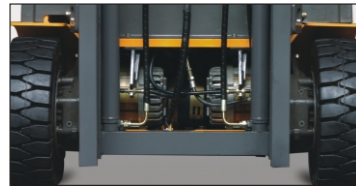

Front-wheel drive through two drive motors incorporated in a compact axle. AC motors are used, depending on truck size and workloads.

Access to the state-of-the-art controllers is easy at waist height, helping to reduce servicing time.



## STEERING

The "On - demand" hydraulic power steering, combined with drive-motor system, gives superb maneuverability with low noise level and low energy consumption . The low steering force required, further enhances operator comfort.

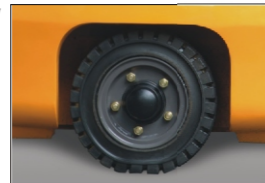

simple. Easy: **SERVICE**

AC: **MOTORS**

state of the art: **ELECTRONICS**

strong, wide, clear view: **MASTS**



## ELECTRONICS

AC technology is better suited to heavy-duty applications. The use of current is optimised and AC motors are brushless, which minimises servicing.

Motors can be very well protected against the water and dust. Roll-back is almost eliminated and higher travel speeds are attainable.

Both systems are fully adjustable to suit the load, the working area and the operator. Inbuilt diagnostics record intermittent faults and service requirements reducing expensive service time.



More than thirty performance parameters can be adjusted to suit the type of load, congestion of the working area and skill of the driver.

# F

Or more than 30 years, HANGCHA GROUP CO., LTD.

Has played a leading role in the manufacture and production of Chinese forklift industry . We constantly strive to develop and incorporate the latest advances in forklift design and technology to ensure that our products provide an optimum level of performance, all the time. Our new generation J series of forklifts truly exemplifies this commitment to excellence.

## INTRODUCTION

The distinctive features of the new J series electric three-wheel forklift are the following :

- Versatility of use due to compact design and minimal operating space requirements. Compact dimensions combined with superb maneuverability.
- High stability, both when stationary and cornering, due to long wheelbase, low centre of gravity and wide tyres.
- Economy of operation, resulting from minimized maintenance costs, e.g. Low-wear brakes.

durable, clean: **HYDRAULICS**  
 simple, comprehensive: **PANEL**  
 wet disc, progressive: **BRAKES**  
 optimised, powerful: **BATTERIES**

### CHASSIS & HYDRAULICS

A fully enclosed chassis frame houses the drive motors. The hydraulic and drive components are protected against dirt and water.

The J series has high quality cylinders and hard chrome burnished and polished rods to reduce seal wear, for long life and minimum fluid contamination.

To keep the oil clean the J has a full-flow low pressure filter on the return line.

Cleanliness minimises seal and pump wear and keeps the control valve in good, trouble free, condition.

### Brakes

The J series three-wheel truck has three independent braking systems:

- Regenerative braking system
- Hydraulic wet disc brake system
- Toggle-type parking brake

### FRAME

Vertical sides help the driver work safely with less damage, even in an area with low-level obstructions.

Thick chassis plates resist distortion, reduce damage and minimise refurbishment costs.

The wide mast and low console give an excellent view of the forks and the way ahead.

Well positioned lights ensure optimum vision to both the front and back-essential in containers.

Much attention has been given to the carriage design, with an integral full-vision side-shift. The cleverly machined structure of tensile steel bars and a double-ended hydraulic cylinder gives the max view of the load and forks, coupled with variable speed side-shift.



The wide mast, low scuttle and high seating position gives the operator an excellent view of the forks and of the way ahead-reducing load damage and accidents.  
An integral full-vision side-shift.

### BATTERY CONTROL

Over 50% of all electric lift trucks bought today are three-wheelers and they have greatest range of applications, from running for just half an hour at one time to working three full shifts a day.

The J series uses only the best control systems. Smaller trucks with less demanding work patterns are fitted with market leading CURTIS controllers.

For heavy-duty trucks, it makes sense to select the CURTIS AC controllers which optimise battery power, particularly helpful on ramps and long runs as well as high lifts.



Full accessible 48 volt batteries with 400-600 Ah capacity are controlled by either CURTIS AC control systems.

### DRIVER'S COMPARTMENT

The J series design pays great attention to the cabin: a strong grab handle is provided, with a large low step for easy access.

A clear footwell with well-placed pedals gives plenty leg room and helps the driver work comfortable.

The simple, concise instrument panel is less distracting yet still offers a comprehensive warning system.

Hydraulic levers can be mounted on either the scuttle or beside the battery, allowing access from either side.

The standard Grammer GS12 semi-suspension seat is a clear benefit for longer shifts or mature operators and gives comfortable support.

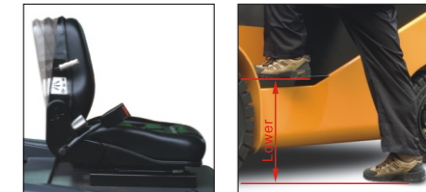

Comfortable seat can be upgraded to a luxury semi-suspension version.  
Safe and easy access is assured by a large, non-slip step and grab handle.  
The adjustable steering Column ensure a comfortable working position.

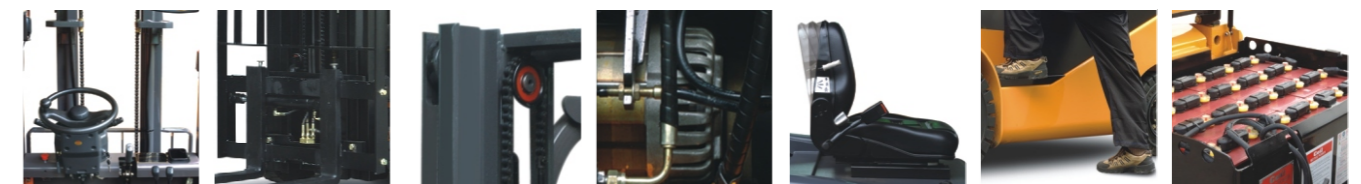

### Standard Feature

- Solid tyre
- Emergency disconnect switch
- Rubber floor mat
- 2 Spools control valve
- Locked spring gas
- Front combined lamp
- 3 meters 2-stage mast
- Adjustable steering column

- Rearview mirror
- Drive, lift, steering controlled
- Rear combined lamp
- Beeper
- Toolbox and file folder
- Hour meter, self-diagnose indicator

### Optional Feature

- 3 or 4 spools control valve
- 4.3-6.5 meters 3-stage mast
- 2.5-4.5 meters 2-stage mast
- With attachment
- Other dimension forks
- High capacity battery
- Special carriage and backrest
- Non-marking tyre
- Battery charger
- Side battery change



### 1.3-2.0 t Electric Three-wheel Forklift Specification

#### DIMENSIONS

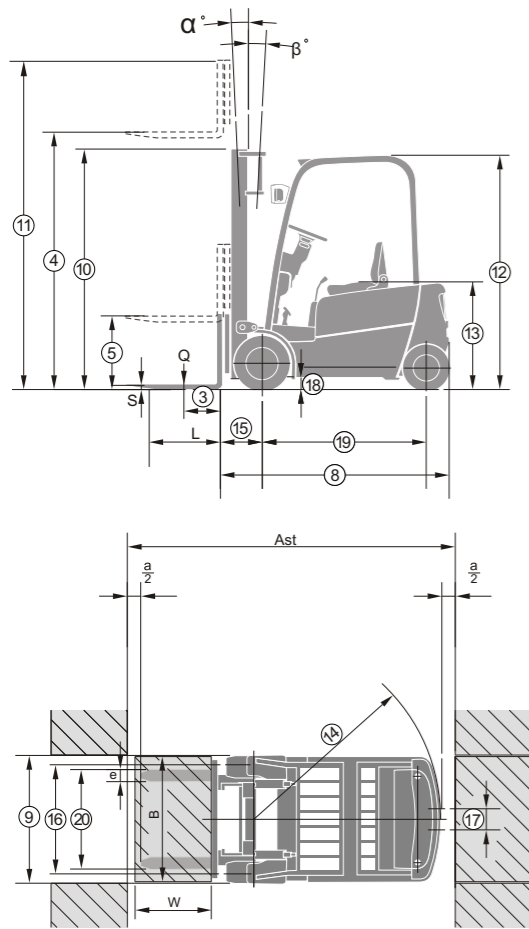

a = 200 mm safety clearance  
 $AST = a + \sqrt{(15 + W)^2 + (B / 2)^2}$

No.	Manufacturer	Kg	HANGCHA GROUP CO.,LTD.					HANGCHA GROUP CO.,LTD.						
			CPDS13J - C1	CPDS15J - C1	CPDS16J - C1	CPDS18J - C1	CPDS20J - C1	CPDS13J - C2	CPDS15J - C2	CPDS16J - C2	CPDS18J - C2	CPDS20J - C2		
1	Model													
2	Rated capacity	mm	1300	1500	1600	1800	2000	1300	1500	1600	1800	2000		
3	Load centre	mm	500	500	500	500	500	500	500	500	500	500		
4	Lifting height	mm	3000	3000	3000	3000	3000	3000	3000	3000	3000	3000		
5	Free lifting height	mm	150	150	150	150	150	150	150	150	150	150		
6	Fork size	s×e×l	40×100×900	40×100×900	40×100×900	40×100×900	40×100×900	40×100×900	40×100×900	40×100×900	40×100×900	40×100×900		
7	Tilting angle	F/B (α°/β°)	6.5 / 6.5	6.5 / 6.5	6.5 / 6.5	6.5 / 6.5	6.5 / 6.5	6.5 / 6.5	6.5 / 6.5	6.5 / 6.5	6.5 / 6.5	6.5 / 6.5		
8	Overall Dimension	Length ( to fork face )	mm	1792	1792	1900	1900	2012	1792	1792	1900	1900	2012	
		Width	mm	1060	1060	1060	1060	1060	1060	1060	1060	1060	1060	
		Height when mast lowered	mm	1995	1995	1995	1995	1995	1995	1995	1995	1995	1995	
		Height when mast lifting	mm	3945	3945	3945	3945	4005	3945	3945	3945	3945	4005	
		Height to safeguard	mm	1960	1960	1960	1960	1960	1960	1960	1960	1960	1960	
	9	Height seat	mm	930	930	930	930	930	930	930	930	930	930	
	10	Turning radius	Min.	mm	1440	1440	1550	1550	1658	1440	1440	1550	1550	1658
	11	Overhang	mm	355	355	355	355	355	355	355	355	355	355	
	12	Thread(Front/Rear)	mm	902 / 175	902 / 175	902 / 175	902 / 175	915 / 175	902 / 175	902 / 175	902 / 175	902 / 175	915 / 175	
	13	Ground clearance	Min.	mm	90	90	90	90	90	90	90	90	90	90
14	Wheelbase	mm	1250	1250	1358	1358	1465	1250	1250	1358	1358	1465		
15	Fork spread	Min. / Max.	mm	200 / 1000	200 / 1000	200 / 1000	200 / 1000	200 / 1000	200 / 1000	200 / 1000	200 / 1000	200 / 1000	200 / 1000	
16/17	Working aisle width	1000×1200 crossways	mm	3161	3161	3271	3271	3380	3161	3161	3271	3271	3380	
18	with pallet (Ast)	800×1200 lengthways	mm	3260	3260	3370	3370	3480	3260	3260	3370	3370	3480	
23	Speed	Travel ( Laden )	km/h	13 (14)	13 (14)	13 (14)	13 (14)	12 (13)	13 (14)	13 (14)	13 (14)	13 (14)	12 (13)	
		Travel ( Unladed )	km/h	13 (14)	13 (14)	13 (14)	13 (14)	12 (13)	13 (14)	13 (14)	13 (14)	13 (14)	12 (13)	
		Lifting ( Laden )	mm/s	300	290	280	270	250	300	290	280	270	250	
		Lifting ( Unladed )	mm/s	450	440	440	430	400	450	440	440	430	400	
	Gradeability	Laden	%	16 (20)	15 (20)	15 (20)	15 (18)	12 (15)	16 (20)	15 (20)	15 (20)	15 (18)	12 (15)	
		Unladed	%	16 (20)	20 (20)	20 (20)	15 (20)	13 (18)	16 (20)	20 (20)	20 (20)	15 (20)	13 (18)	
24	Service weight	Include battery box	Kg	2760	2950	3020	3080	3370	2760	2950	3020	3080	3370	
25	Tyre	Front×2		18×7-8	18×7-8	18×7-8	18×7-8	200 / 50-10	18×7-8	18×7-8	18×7-8	18×7-8	200 / 50-10	
		Rear×2		15×4.5-8	15×4.5-8	15×4.5-8	15×4.5-8	15×4.5-8	15×4.5-8	15×4.5-8	15×4.5-8	15×4.5-8	15×4.5-8	
26	Motor	Driven motor×2 /S 60min	kw	4.75×2	4.75×2	4.75×2	4.75×2	4.75×2	4.75×2	4.75×2	4.75×2	4.75×2	4.75×2	
		Pump motor /S 15min	kw	8.6DC	8.6DC	8.6DC	8.6DC	8.6DC	8.6AC	8.6AC	8.6AC	8.6AC	8.6AC	
	Battery	Standard	V/Ah	48 / 400	48 / 400	48 / 500	48 / 500	48 / 600	48 / 400	48 / 400	48 / 500	48 / 500	48 / 600	
		Optional	V/Ah	48 / 440	48 / 440	48 / 550	48 / 550	48 / 660	48 / 440	48 / 440	48 / 550	48 / 550	48 / 660	
27	Controller	Drive system		AC	AC	AC	AC	AC	AC	AC	AC	AC	AC	
		Manufacturer		Curtis	Curtis	Curtis	Curtis	Curtis	Curtis	Curtis	Curtis	Curtis	Curtis	
28	Operating pressure for attachment	Mpa	14.5	14.5	14.5	14.5	14.5	14.5	14.5	14.5	14.5	14.5		

- Special lifting height available.
- Attachment available.
- The specification in the table are for standard models only.  
For further information please contact us.
- Specifications are subject to change without notice.



#### LOAD CHART

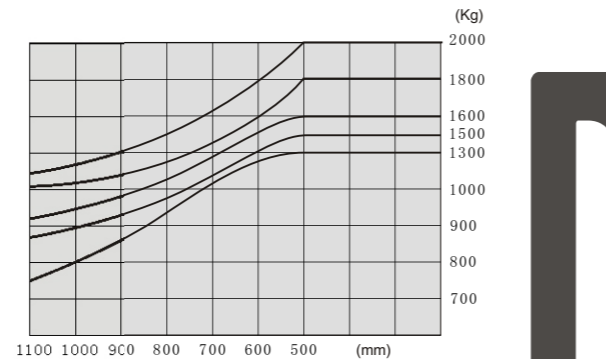

#### 1.3 / 1.5 / 1.6 / 1.8 / 2.0 t J serise mast

Type	Model	Mast fork height	Overall height				Free lift		Tilt range		Capacity				
			Lowered	Extended		Extended		FWD	RWD	Load capacity at 500 mm					
				With backrest	Without backrest	With backrest	Without backrest			1.3T	1.5T	1.6T	1.8T	2.0T	
Wide view 2-stage mast	S16MX	2500	1745	3445	3065	145	145	6.5	6.5	1300	1500	1600	1800	2000	
		2700	1845	3645	3265	145	145	6.5	6.5	1300	1500	1600	1800	2000	
		3000	1995	3945	3565	145	145	6.5	6.5	1300	1500	1600	1800	2000	
		3300	2145	4245	3865	145	145	6.5	6.5	1300	1500	1600	1800	2000	
		3500	2245	4445	4065	145	145	6.5	6.5	1300	1500	1600	1800	2000	
		3600	2295	4545	4165	145	145	6.5	6.5	1300	1500	1600	1800	2000	
		4000	2545	4945	4565	145	145	3.5	5	1300	1500	1600	1800	2000	
		4300	2710	5245	4865	145	145	3.5	5	1200	1400	1500	1700	1900	
		4500	2820	5445	5065	145	145	3.5	5	1100	1300	1400	1600	1800	
		2-stage full free mast (with side shift)	S16UX	2500	1745	2955	3105	550	900	6	6	1300	1500	1600	1800
2700	1845			3155	3305	750	1100	6	6	1300	1500	1600	1800	2000	
3000	1995			3455	3605	1050	1400	6	6	1300	1500	1600	1800	2000	
3300	2145			3755	3905	1350	1700	6	6	1300	1500	1600	1800	2000	
3500	2245			3955	4105	1550	1900	6	6	1300	1500	1600	1800	2000	
3600	2295			4055	4205	1650	2000	6	6	1300	1500	1600	1800	2000	
4000	2545			4455	4605	2050	2400	3.5	5	1300	1500	1600	1800	2000	
Wide view full free 3-stage mast	S16NX	4300	2010	5245	4905	1100	1415	3.5	5	1200	1400	1500	1700	1900	
		4500	2075	5445	5105	1170	1480	3.5	5	1100	1300	1400	1600	1800	
		4800	2175	5745	5405	1270	1580	3.5	5	1000	1200	1300	1500	1550	
		5000	2240	5945	5605	1340	1645	3.5	5	950	1150	1250	1450	1500	
		5500	2410	6445	6105	1500	1815	3.5	5	850	1050	1150	1200	1300	
		6000	2625	6945	6625	1670	2010	3.5	5	750	950	1050	1100	1200	
		6500	2810	7456	7135	1680	2180	3.5	5	550	750	850	900	1000	

Note: With side-shift, load capacity subtract 200Kg.